

**CODE:** P432901  
**Item:** Adapter for Insulation Piercing Connector AD-12

## PRODUCT TECHNICAL SPECIFICATION

**Description:** Adapters for Insulation Piercing Connectors are used in combination with Insulation Piercing Connectors for branching of branch lines which may be separately connected or disconnected without removing the Insulation Piercing Connector from the network. At the branch line is necessary to remove insulation in the length designated on the adapter.



**Conductor cross-section:** 2x(6-35) mm<sup>2</sup>  
**Conductor diameter:** 2.7-7.3 mm  
**Tightening torque:** 5 Nm (shear-head)

### Dimensions

**a [mm]** 95  
**b [mm]** 48  
**H [mm]** 87

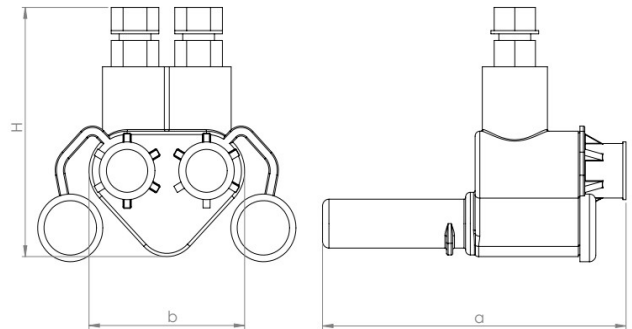

### Other characteristics

**Elec. contact material:** Aluminum alloy  
**Body and sealant:** Weather, UV resistant and water-tightness elastomer  
**Nut with share-head:** Aluminum alloy/Weather and UV resistant Polyamide, 13mm  
**Required tools:** 13 mm wrench  
**Marking:** The length of removing the insulation from the cable, Date  
**Standard:** EN 50483-4

### Packing:

**Product weight:** 99.56g per piece  
**Bag packing:** - pcs  
**Box packing:** 50 pcs  
**Box BRUTO weight:** 5.47 kg



8605031011517