

**CODE:** P801808  
**Item:** Anchoring clamp PA25

## PRODUCT TECHNICAL SPECIFICATION

**Description:** Clamp is designed for tension of messenger lines of overhead ABC cables to poles or walls by hanging on standard hooks and brackets. Mostly, this clamp is used for tensioning the ABC cable from pole to household connection.



**Cable cross-section:** 2x(10-35) mm<sup>2</sup>  
**Cable diameter:** 2x(5,6-10.9) mm  
**SMFL:** 2 kN

### Dimensions

**a [mm]** 18 ± 1 mm  
**l [mm]** 63 ± 1 mm  
**L [mm]** 170 ± 1 mm

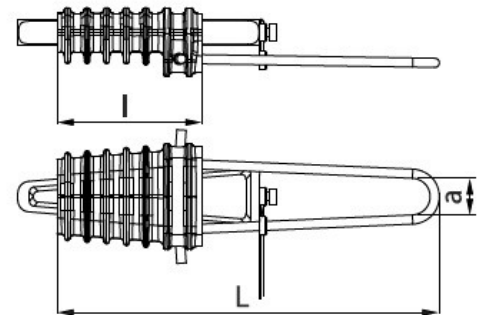

### Other characteristics

**Body:** Weather and UV resistant Polyamide  
**Wire:** Galvanized steel (other per client request)  
**Required tools:** No tools required  
**Marking:** PLAMEN, 10-35, P801808, Date  
**Standard:** EN 50483-2

### Packing:

**Product weight:** 71.20g per piece  
**Bag packing:** - pcs  
**Box packing:** 100 pcs  
**Box BRUTO weight:** 7.61 kg

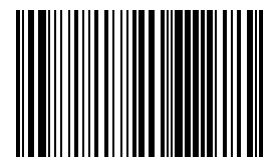

8605031013597